

# The Care and Feeding of the R.F. Isolator

By:  
William F. Lieske, Sr.  
Founder, EMR Corporation

---

## Introduction

Over the past thirty years or more the number of receivers and transmitters at established wireless system repeater sites has increased many times over. The number of antennas found on towers and building tops has also increased despite the application of transmitter combining and receiver multicoupling techniques.

As the conversion from analog to digital modulation methods takes place, the effects of interference to signal reception as the result of mixing of both digital and analog transmitter signals in power amplifier stages becomes even more of a problem than in the past.

The application of suitable R.F. isolators with complementary filtering devices now becomes even more important as this change in technology progresses.

The purpose of this bulletin is to review the characteristics of R.F. isolators and their operation and discuss the ways in which these devices are applied to control interference due to intermodulation products and to provide other benefits. A better understanding of R.F. Isolators, their benefits, limitations and shortcomings and the best ways to employ them will be covered in this bulletin.

## What Are R.F. Isolators?

These devices have been used in land mobile (wireless) systems for more than three decades. The need for them has increased almost exponentially as complex, multichannel systems have developed, particularly during

the past fifteen years. The availability of suitable locations for the operation of such systems is limited by geographic characteristics in most areas, leading to the clustering of up to hundreds of transmitter-receiver combinations at a common site.

Most transmitting R.F. power amplifiers in use today are solid state types, using power transistors or power FET components. The need for a high order of operating efficiency determines that these components are operated in "Class C" mode. This results in a non-linear condition in which signals from one or more nearby transmitters can be coupled into a given P.A. and mix with the desired signal to produce unwanted spurious signals. The unwanted signals can result from the products generated through mixing the fundamental signal frequencies and/or the various harmonics of the constituents signals.

All too often, the unwanted signals fall on or near receiving channels at the operating site and are of sufficient strength to cause destructive interference to the conduct of normal and desired reception of voice and data. This phenomenon of this signal mixing is called *intermodulation* or "I.M." interference. Isolators are one of the key components used to help control this form of interference.

Along with cavity resonators, harmonic or low pass filters, isolators provide a solution to interference problems that would otherwise destroy effective communications. Isolators have become an important tool for use in modern wireless system site management and interference control work.

## The Care and Feeding of the R.F. Isolator

### Isolators: What they are, how they work

The basic R.F. Isolator is made from a device called a *circulator* with a *matched load termination* (See Figure 1). The circulator consists of ferrite materials, magnets, inductors and capacitors according to the band of operation, input power rating, and intended application.

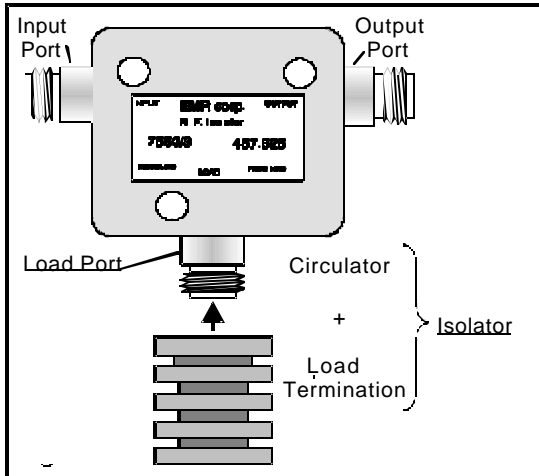

Figure 1

The best designs include sturdy plated steel cases that provide high immunity to outside magnetic influences. Careful thermal compensation is used to limit drift under high operating duty cycles and high ambient temperatures. The load termination is typically a beryllium rod or rectangular body on which carbon has been applied in a special manner with suitable contacts to form a R.F. power dissipating resistor. This element is enclosed in a suitable load body made from copper, aluminum or brass and equipped with heat sink fins to aid in dissipating heat.

This combination of a circulator and a load termination becomes a device that conducts R.F. power in a forward direction from a transmitter's output to an antenna feed line with very low loss of power due to attenuation. Any R.F. signal that is reflected from the antenna system due to mismatch or de-

tuning or coupled into the antenna from adjacent transmitting antennas will "see" a high loss path toward the transmitter but a low loss path toward the load termination (See Figure 2).

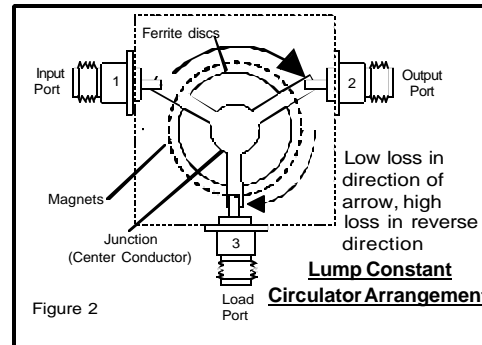

Figure 2

Reflected power is prevented from reaching the transmitter power amplifier stage where it could impair the performance of the amplifier stage. In case of a coupled signal, mixing in the P.A. stage is controlled to reduce or eliminate signals known as *intermodulation* or "I.M."

Intermodulation products are generated when two or more signals are mixed together in any electrically non-linear device (such as a diode). Most modern solid state R.F. power amplifiers employ transistors or power FET's operated in class "B" or "C" mode for the sake of electrical efficiency. They are found to be effective signal mixers, often exhibiting less than 10 dB mixing conversion loss.<sup>(1)</sup>

Isolation between the system antenna and a power amplifier may be provided by a single stage isolator. This is found to be at least 20 dB and often higher than 30 dB in higher grade isolators. Isolators may be cascaded to secure needed system isolations and both the insertion loss and isolation properties of the individual units are additive. Dual and triple section isolators are found in today's market,

(1) Conversion loss is the difference between the lesser strength of two signals as mixed together and the relative strength of the resulting heterodyne product(s).

## The Care and Feeding of the R.F. Isolator

providing as much as 100 dB of isolation. Typical insertion loss is under 0.30 dB and can be as low as 0.10 dB *per junction* in high quality units.

### Circulator and Isolator Types

There are two types of circulators in current usage: *Distributed Constant* (sometimes called “*distributive*” constant) and *Lumped Constant*. The difference in these types is found in the coupling method used to apply and recover R.F. energy from the ferrite material.

In the distributed constant type, two relatively large planes of ferrite material are arranged either as thin triangles, discs or hexagonal shapes. A conductor having three arms is interposed between these ferrite bodies. This element, referred to as a “center conductor” or “junction”, connects to terminals, typically coaxial connectors.

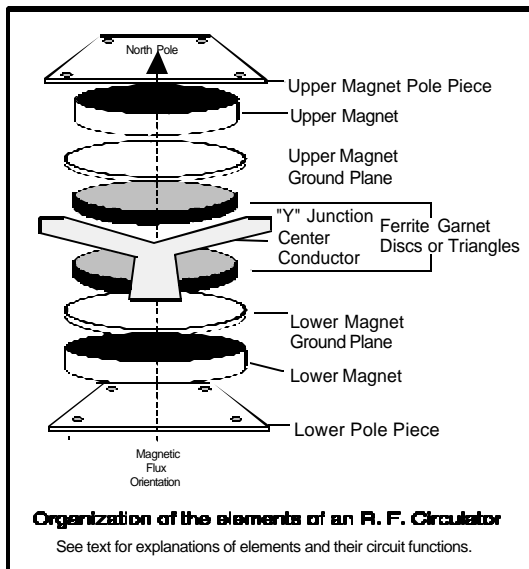

Figure 3

As seen in Figure 3, flat magnets, changed and polarized as shown, are arranged with mild steel “ground planes” and “pole pieces”

to concentrate magnetic flux through the assembly, magnetically *biasing* the garnet material.

This assembly is then placed in an enclosure with three coaxial connectors, becoming a *single junction circulator*. Two junction assemblies are arranged in a single case to form a dual unit and three assemblies for a triple unit. There are significant savings in materials and the performance is better in multi-junction units compared with having two or three single units tied together with cables or adapters.

Views of an EMR Corp. medium power dual isolator are shown in Figure 4. This same style is used for up to 150 watt transmitter power inputs in bands from 66 through 1.3 GHz. The unit shown has a 30 watt load termination at the input section and a 60 watt termination at the output section. Load termination ratings will be discussed further, later in the bulletin.

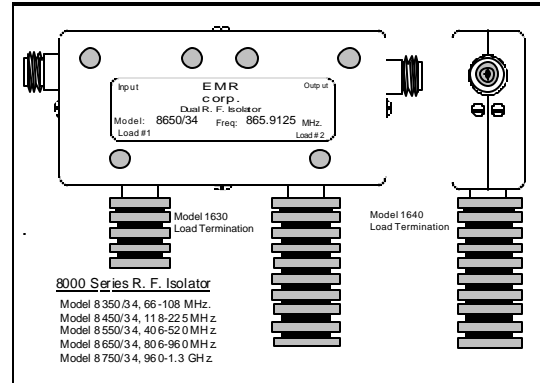

Figure 4

### Higher Power Isolators

Two hundred fifty watt rated single and dual junction isolators are provided for frequency ranges from 72 through 960 MHz. EMR Corp. supplies single junction 500 watt continuous duty rated units for 88-108 (FM Broadcast) and high power paging application on the 150-174, 450-470 and 928-932 MHz ranges.

## The Care and Feeding of the R.F. Isolator

Development work on 1,000 watt and higher power isolators is being continued currently (January, 1999).

### System Applications

Wireless land mobile communications sites have been established on literally every available high building, hill top or mountain top as well as on towers erected for the purpose. There are many other desirable locations that could serve as remote sites, however, government and private ownership tends to limit this usage mainly due to aesthetic motives.

Although the general public, business and government wants and needs the benefits of long range wireless communications, towers and antennas are considered "ugly" to many environmentalists. This has contributed to severe over population of existing sites with new equipment, operating on new frequencies and new antennas. With less than adequate availability of channels within popular land mobile bands, every conceivable combination of frequencies and system types might be found at any given site.

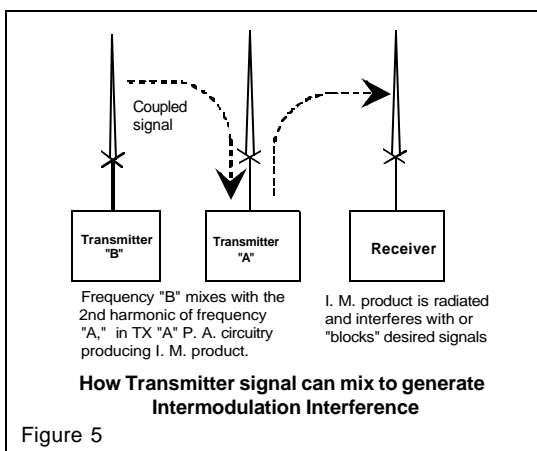

We find sites with just a few to *hundreds* of repeaters in operation. Generally after the first five or six repeaters are installed at a given

site without the application of proper site planning, some kind of interference is experienced. Inadequately filtered wide band transmitter noise will very often cause desensitization of receivers, transmitter carrier power will "crunch" the front end of the receiver and intermodulation products will result in erratic performance, "squeaks" and "squawks" and other interference forms that destroy peaceful and effective communications.

Figure 5 shows how signals from two transmitters can mix to generate intermodulation interference to a nearby receiver.

Given: Transmitter A = 461.725 MHz.  
 Transmitter B = 463.815 MHz.  
 Receiver = 459.635 MHz.

Note that the 2nd harmonic of transmitter **A** is 923.450 MHz. If we subtract the transmitter **B** frequency the result is 459.635 MHz., the receiver's frequency .

This is called a "3rd Order" intermodulation product. We name these according to the harmonic number of constituent frequencies involved in the mix, in this case 2 times **A** minus **B**. Where other harmonics are involved,  $3A - 2B$  which is the 3rd Harmonic of **A** less

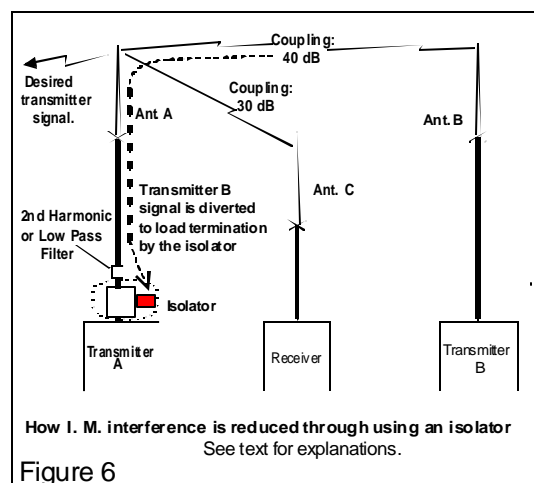

## The Care and Feeding of the R.F. Isolator

the second harmonic of **B**, etc. In Figure 6 we see an expanded version showing the addition of an isolator. Were it not for the isolator placed in the Transmitter A feed line, the Transmitter B signal would be attenuated only by the antenna-to-antenna de-coupling factor and the transmission line losses. From 30 dB to 35 dB of isolation can be provided per isolator section.

### Calculating I.M. Signal Levels

Assume transmitters **A** and **B**, 6 dB of "gain"<sup>(2)</sup> for each antenna, and a 12 dB SINAD receiver sensitivity<sup>(3)</sup> of 0.20 micro-volt (-113 dBm). We can factor these elements to arrive at signal power levels. Measurements in "dBm" (dB referenced to 1 milli-watt) will be used to show signal power and "dB" to indicate gains and losses.

	Power Gain	Power Loss
TX "A" Power, 100 w.	-----See Text-----	
Coax Line "A" Loss	-	2.0 dB
Antenna "A" Gain	+6.0 dB	-
Antenna "B" Gain	+6.0 dB	-
Coax Line "B" Loss	-	2.0 dB
TX "B" Power, 100 w.	+50.0 dB	-
Coupling Factor, Ant. "A" To Ant. "B" <sup>(4)</sup>	-	40.0 dB
TX "A" conversion loss	-	10.0 dB
Coax Line "B", Loss	-	2.0 dB
Sub Totals:	+62 dBm	56.0 dB

**Net signal power of I.M. Product:**  
**(+62 dBm--56 dB)** = **+6.0 dBm**

This will suggest the level of the generated 3rd order product. To get the whole picture, we can complete the comparisons as follows:

	Power Gain	Power Loss
Gain, RX Antenna	+6 dB	
RX antenna line loss		-2 dB
Coupling loss, Antenna A to Antenna B		-55 dB
Sum of gains & losses	+6 dB	-57 dB
<b>Net Gain/Loss</b>		<b>-51 dB</b>

Net signal power of the +6 dBm I.M. product will be reduced to: (+6 dBm--51 db) -45 dBm

Comparing this level to receiver sensitivity will tell us how much additional isolation is required to fully suppress the I.M. products:

Receiver Sensitivity @ squelch threshold -0.2 microvolt:=	-113 dBm
I.M. Product signal level	-45 dBm

**Added system isolation needed to bring I.M. products at or below the Receiver's sensitivity:** **68 dB**

We have found that I.M. interference always changes over time and usually gets worse. For this reason we would add at *least* 10 dB of isolation to the calculated number to provide some "head room". For this case, we would design to 80 dB of added system isolation.

### Where The I.M. Product is Actually Generated

Looking again to Figure 6 note that the interference is due to the 2nd harmonic of transmitter "A" mixing with the fundamental frequency of transmitter "B" to yield the I.M. product. In this case the offending mix takes place in the output transistors in the power amplifier stage of transmitter "A", where rich harmonic energy will be present.

---

(2) Antenna "gain" is actually the improvement in signal performance of multi-element antennas that enhance signal due to focusing or beam forming, expressed in dB, compared to dipole antennas.

(3) The accepted method of rating receiver sensitivity in narrow band FM systems. SINAD stands for Signal Input (plus) Noise And Distortion.

(4) Best measured directly, however, can be estimated with reasonable accuracy from nomographs.

---

## The Care and Feeding of the R.F. Isolator

This harmonic energy level will depend, as suggested earlier, on the components used, circuit design and similar factors. *All F.C.C. type approved transmitters* must include sufficient low pass filtering to reduce all harmonics below a level at least 80 dB of carrier output, which is accomplished by a low pass multi-section filter. Such filters have sufficient rejection to meet F.C.C. requirements for 2nd harmonics and higher.

Since the second carrier that can be mixed is within the filter pass band it will be conducted back through the low pass filter into the P.A. circuitry with only minor attenuation. It can now mix, producing I.M. interference. As noted earlier, the resulting I.M. signal level will be less than the coupled (transmitter B) signal according to the conversion loss of the particular P.A.

The resulting I.M. product, being in-band, will be conducted to and radiated by the transmitter's antenna. The mix, in this case takes place in the transmitter "A" power amplifier stage. Both transmitters must be active to provide the frequencies that can mix.

### Getting Needed System Isolations

In the previous example, we found that we need 80 dB of isolation added into the system to reduce the I.M. level safely below the receiver's squelch threshold. We can employ several means to accomplish this:

1. Place a multi-section isolator having 80 dB or more of isolation between transmitter "A" and its antenna feed line. This is one of the better ways to control the problem.
2. Secure added de-coupling between the problem channel frequencies with cavity resonators, either band pass or pass-reject types.

3. Change relative antenna positions to secure additional decoupling.

4. Employ a suitable combination of the above three ways of securing isolation as needed to solve the problem.

It is good practice to use any combination of devices that will accomplish the desired result with the least amount of wasted signal power due to filtering losses.

### Other Sources of I.M. Products

Any electrically non-linear device can produce I.M. interference. Oxides or sulfides of some metals can exhibit semiconductor characteristics. We have found rusty door hinges, oxidized roof flashing, rusty towers and guy wires, discarded cable, wire and hardware on the ground around a site, improper grounding and other sources of mixing that caused intermodulation interference.

Isolators will not, as a rule, help in these cases. The point(s) of mixing must be found and corrected.

Good housekeeping and site cleanliness will go a long way toward preventing such problems. Most major sites now have owner-user associations which hold inspection and clean up days on a scheduled basis to insure proper site conditions.

### About Cavity Resonators <sup>(5)</sup>

Cavity resonators are another important tool for use in interference control.

The cavity resonator consists of an adjustable length resonator rod, analogous to a 1/4 or 3/4 wavelength antenna, placed inside a

---

(5) See: Methods of Tuning Cavity Resonators According to Application, beginning on page 54 of this publication.

## The Care and Feeding of the R.F. Isolator

suitable housing. The shape of the housing can be square, round, triangular or irregular in shape; the volume of it and material used for the most part determining the performance for a particular frequency range and at a given coupling loss factor. Most often, aluminum is used for the cavity body, due to its availability and adaptability. Copper or brass is sometimes used for body shell and usually for the resonator and loops, these usually being silver plated to minimize skin effect losses.

Most cavity resonators employ a frequency adjusting rod made of INVAR, an alloy having near zero expansion/contraction due to temperature change. For band-pass service, two loops are placed at the tuning end of the cavity and opposite from each other, on either side of the resonator element such that one couples R.F. energy into the cavity and the other couples energy out of the cavity. Often, the loops are rotatable, providing a convenient way to adjust coupling factor.

Selectivity of a band-pass cavity vs: coupling loss factor relies on the volume of the cavity body and R.F. surface conductivity of the materials used. For pass-reject use, a single loop is often used with a series capacitor that will tune the loop itself as a trap to reject unwanted frequencies. The higher the cavity "Q", e.g.: the greater the volume, the sharper will be the notch at a given notch coupling factor and the closer will be the capability of notching close to the desired pass band.

Figure 7 shows a cross section of a typical band pass cavity resonator with identification of its elements.

Thermal compensation is accomplished through placement of the fixed point of the invar rod. Micro-movement of the tuning element over many years of temperature change can cause the "finger stock" used between the fixed and movable segments of

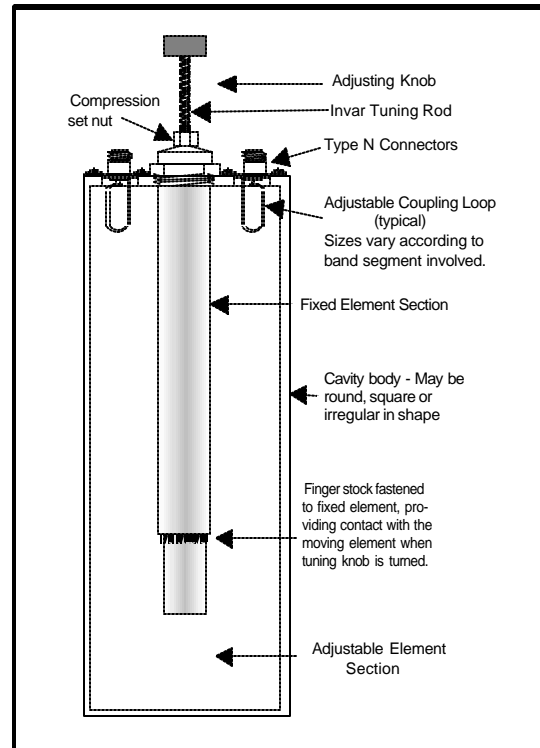

Figure 7 Cavity Cross Section

the tuning element to wear through the silver plating. Differences in contact resistance then often results in a noisy, unstable device. In most cases it is found that taking old cavities apart and having these elements replated is not justified from a cost standpoint.

### Isolator-Cavity Combinations

Where a number of transmitting antennas are to be closely spaced on a horizontal plane, a combination of a selected band pass cavity and dual isolators can provide high amounts of signal rejection over a rather large band of frequencies. An added benefit is that the isolator provides a 50 ohm load impedance for the transmitter P.A. to "see". This promotes P.A. linearity and stability.

## The Care and Feeding of the R.F. Isolator

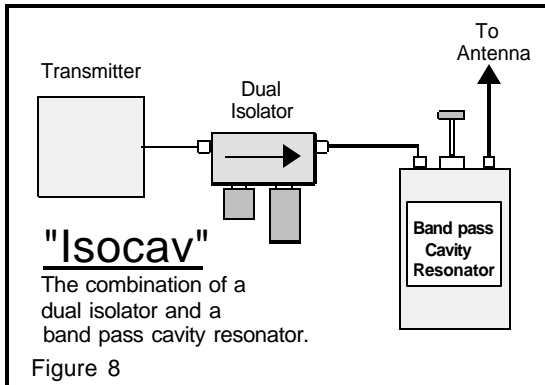

Figure 8 shows the arrangement of a dual isolator and a band pass cavity resonator in combination placed between the transmitter output and the antenna feed line. Note that the isolator is fed by the transmitter and that the output of the isolator feeds the cavity resonator. The reasons for this arrangement will be covered later.

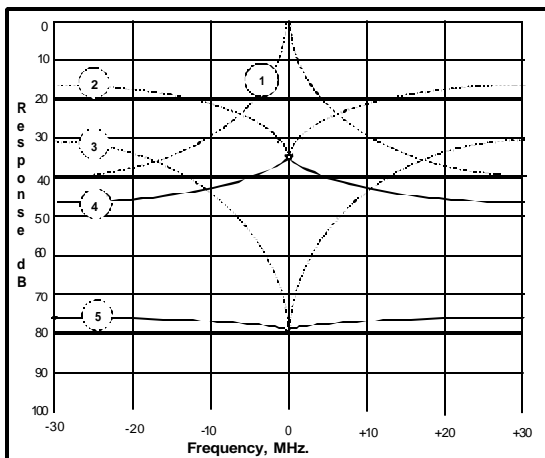

Figure 9

The resulting characteristics were graphed under wave analysis centered on 470 MHz. and are shown in figure 9.

Curve #1 shows the response of the band pass cavity resonator set for 1 dB of coupled loss. Curve #2 shows the isolation curve of a single junction isolator. Curve #3 shows the isolation response of a dual stage isolator.

Curve #4 is the response of curve #1 plus curve #2 showing 37 to 46 dB of isolation over a 60 MHz. segment of spectrum. Curve #5 combines curve #1 and curve #3 which provides 75 to 80 dB of isolation over the 60 MHz. range.

With proper cavity coupling adjustments more than 80 dB of isolation will be realized with less than 1.5 dB overall insertion loss using this filtering combination over a similar frequency range. EMR Corp. supplies these combinations as "Iso-Cav's" for all popular land mobile communications frequency bands and for transmitter power up to 500 watts.

### Some Do's And Don't In The Application of Isolators

All electrical or electronic components have some kind of limitations. Isolators are designed and manufactured for specific applications in which they provide outstanding benefits. Still we find a surprising lack of understanding or sensitivity as to why and how isolators are applied in the field for the greatest benefits and highest reliability.

Let's discuss various considerations of these devices, their good points and their limitations.

### Power Input VS: Duty Cycle

Isolators are designed and sold to meet a target system power and function under a specified transmitter duty cycle.

Twenty or more years ago the great majority of systems operated on a dispatch basis using simplex or half duplex modes of operation in which actual transmitter duty cycles rarely, if ever, exceeded 25% with the possible exception of radio paging transmitters and the now extinct "IMTS" radio-telephone systems.



## The Care and Feeding of the R.F. Isolator

The industry's move toward wire line interfacing and "trunked" systems has resulted in duty cycles that can reach 100% during the typical service day of operations, e.g.: 7:00 A.M. through 7:00 P.M. Although many isolators were originally rated for E.I.A. intermittent duty cycle (one minute on and four minutes off) the majority of modern systems now require 100%, continuous duty operation without degradation in performance.

**Tip #1:** Make sure that the isolator selected is capable of the required performance at the *system duty cycle concerned*.

### Effects of Temperature On Isolators

The ferrite and magnet compositions that are used in isolators are, by nature, somewhat unstable in performance characteristics over temperature ranges. The ferrite materials become stronger, in effect, and magnets become weaker as temperature rises. These characteristic changes are not equal and opposite nor do they change linearly over relatively wide temperature excursions.

The ferrite garnets are compounded from some rather exotic and rare base elements, such as yttrium iron and have been "doped" with various elements such as calcium, vanadium, gadolinium and other elements to yield desired electrical performance as well as best temperature characteristics. Ceramic based magnets are compounded from many base metals such as iron, nickel, barium, strontium and other selected elements.

Where the isolator might be installed such that wide ranges of ambient temperature can occur, some means must be devised to compensate for the temperature characteristics of the basic elements as well as the thermal behavior of the overall mechanical assembly.

Various special alloy metal pieces that exhibit magnetic conductivity change or special thermally sensitive ferrites can be used as temperature correcting tuning components. Attention to the behavior of all materials used are important if extended duty cycles and an elevated ambient temperature are to be met with stable performance.

External heat sinks and cooling fans can extend the performance range of medium duty cycle isolators by a significant amount. Through the use of forced air cooling, an isolator can be operated at extended duty cycles even under high ambient temperature conditions.

**Tip #2:** Be sure that the isolator that you select will handle the power applied at the highest duty cycle expected and that it will remain stable over the range of temperature to be experienced.

### Sizing Load Terminations

Earlier in this bulletin we touched on the subject of determining the heat dissipation rating of isolator load terminations. Since the load termination at each "load" port must dissipate any power circulated to it as heat, we must determine the maximum amount of power to be dissipated in every application.

Dry dielectric resistor elements are, by and large, made from beryllium squares or rod forms with carbon deposited on them in amounts needed to yield target resistance values and to withstand the currents and voltages associated with the maximum dissipated power. To be effective, the resistor elements must be fastened to a heat sink having sufficient area to radiate the heat away to the atmosphere.

## The Care and Feeding of the R.F. Isolator

We use terminations rated from 0.5 through 500 watts in today's wireless applications. Using an example of a dual medium power isolator that will have 100 watts applied and up to a continuous duty cycle we have developed some rules, as follows:

- ◆ The input section load termination rating should be not rated below 20% of the power input to the isolator. This will ordinarily allow for worst case power dissipation due to mismatch of the transmitter or improper cable length between the transmitter output and the isolator input.
- ◆ The output section load termination should be rated to at least 50% of the input power to the isolator as a general rule. Where the possibility exists that high levels of reflected power due to antenna icing or failure of antenna or lines rating the termination should be rated at 75% to 85% of input power to the isolator, depending on application.

To examine the reasons for these selections, consider the following:

### Medium Power Dual Isolator Input Port

With 100 watts of power applied at input:

-Insertion loss, 1st junction, 0.2 dB	4.4 watts
-Power circulated to input load port with 2:1 VSWR mismatch at input port	19.25 watts
-Max. power reflected from input of second section (based on 26 dB return loss at conjunctive match)	5.0 watts
Total	28.65 watts

We would assign the next highest rated termination: EMR Corp. 30 watt unit to this port. For the output port load termination on a 100 watt medium power dual isolator we find:

### Medium Power Dual Isolator Output Port.

With 100 watts of power applied at input:

-Insertion loss, per junction, 0.2 dB two junctions	Loss: (8.8 watts)
- Max. power reflected from antenna system @ 3:1 VSWR	70 watts
-Path loss, circulated from output port to load port, 0.2 dB	(4 watts)
Total (70 - 12.8)	= 57.20 watts

A 60 watt termination would be used here, however, if there would be chances that antenna icing could de-tune the antenna system a 75 watt termination would probably survive the worst case condition.

**Tip #3:** Consider the worst case site conditions when selecting isolator load termination ratings.

### **Physical Placement of Isolators**

At EMR Corp., we have developed our full line of products to include "Iso-panels" and transmitter combiners, all of which employ isolators as a key component. We have made them as compact as possible, consistent with access to input and output connectors, best electrical performance and proper heat management. In all of these designs the protection of the isolator has been considered. Here are some more tips regarding the placement of Isolators:

Don't mount isolators out of doors and unprotected. Except for very special models, they were designed for indoor, protected installation, only.

Don't simply hang an isolator by its connectors, on the back of a transmitter or on a cavity filter. It probably will not be matched to the circuit properly and if mounted this way will be vulnerable to connector damage or other damage due to inadvertent bumping or cable strain.

## The Care and Feeding of the R.F. Isolator

Don't mount an isolator on or near fan motors or power transformers. Even if the isolator is magnetically shielded, strong A. C. field can effect its characteristics and even demagnetize the internal fixed magnets, causing complete de-tuning.

Don't mount an isolator such that free air flow around it and its load terminations is restricted. Room temperature air must be allowed to circulate freely around the device for proper cooling.

Don't attempt "tweaking" the tuning capacitors on tunable isolators unless you understand how they function and have the required test equipment. Ask for the EMR Bulletin: Field Tuning of Isolators.

### More About Transmitter P.A. Stages

Earlier in this bulletin we mentioned that an isolator will provide a correct load for a transmitter P.A. stage, promoting higher efficiency of operation and better stability. But, an isolator cannot correct for changes in effective P.A. output impedance as a function of its operating parameters.

Solid state amplifier designers must deal with the characteristics of the devices available to use and deal with the class of operation of these devices in their designs. If a P.A. stage is designed to produce a given power output level, say 100 watts, the design engineer will usually arrange circuit elements to provide a  $50\ \Omega$  output impedance at the output port and at the design output power. Since the active devices are usually operated in "Class C" mode and the stage gain is fixed, the output power is determined by the level of the drive to the transistors or power FET's employed.

With no excitation, these stages draw little or no current and consume very little power from the power source. Where driving power is

lower than that which produces the target output power, the current drawn from the power source is lower resulting in an effective dynamic impedance shift to some higher value. Conversely, if you try to squeeze more than the design power out of the P.A. and get, say 125 watts of it's output impedance will lower and it's components will be unduly stressed.

In either case, the P.A. will no longer match the  $50\ \Omega$  impedance of the isolator, resulting in some power being reflected back toward the P.A. circuitry, sometimes resulting in the formation of spurious signals. The lesson, here, is that you should always select an amplifier that is designed for the power level that you intend to operate it in your system. *Don't operate it at any level more than 5% from the rated power that it was designed for.*

One indication of P.A. impedance mismatch is heating of an isolator's input load termination. This can be aggravated by the chance length of cable that could magnify the mismatch due to linear transformer effects.

We do have a fix for this, however, in the form of a little network that we call a "Line Matcher". Others call a similar device "Z Matcher", "Micro-Matchers" or similar names. Figure 10 shows an EMR Corp. Line Matcher along with it's equivalent "PI" Network schematic.

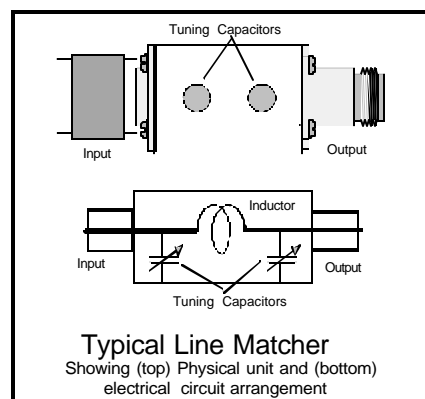

Figure 10

## The Care and Feeding of the R.F. Isolator

The Line Matcher is most properly placed right at the P.A. output connector with a length of cable to the isolator. The best way to adjust the matcher is to place a watt-meter between the isolator output and an antenna or load termination, then alternately adjust the matcher's tuning capacitors for maximum forward power.

The best match with the P.A. is found when maximum power is conducted to the isolator input. The "PI" network configuration of the Line Matcher permits you to find the most agreeable match. Usually most cable lengths can be "tuned" in this way, however, on occasion a length is found to be impossible to tune. In this case you must either lengthen or shorten the cable by an approximate 1/4 wavelength in the center of the band of operation.

### Isolator Harmonic Suppression

Weak harmonics of the input signal frequency to an isolator can be found at the output of the device. This phenomena is thought to be the result of minor impurities in the ferrite material. It can be measured, however, and the worst case that we have found is 52 dB below the level of the conducted carrier level out from the isolator. Third and higher order harmonics are present but at least 95 dB down and usually more than 100 dB down.

With two or more carriers applied simultaneously to an isolator's input port I.M. products as strong as 65 dB below the weaker of the two carriers have been measured, suggesting a conversion loss effect of 10-12 dB. From this we conclude that at least 40 dB of suppression of the 2nd harmonic is in order to keep all I.M. products to at least 100 dB down. The 2nd harmonic filter shown in Figure 11 is well suited to this requirement and is a simple and relatively inexpensive solution to the problem.

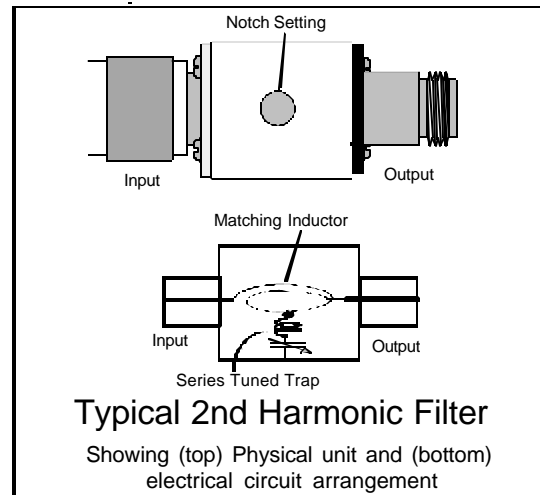

Figure 11

Where the ultimate of protection is desired, including the rejection of all harmonics and spurious signals the use of a low pass filter as shown in Figure 12 is recommended.

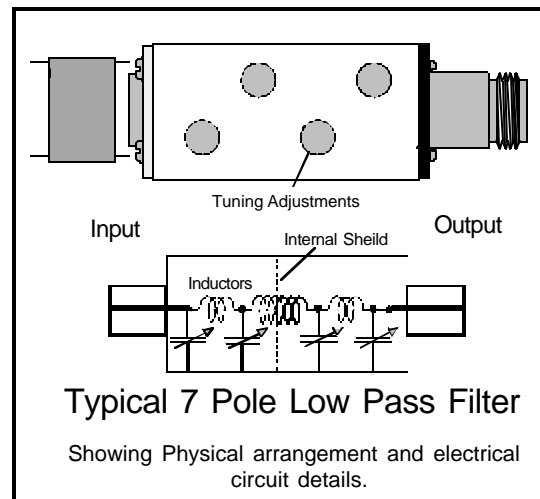

Figure 12

The responses of both filter types are shown in graph form in Figure 13. Note the following: (400 - 470 MHz filters used).

Trace #1 is the response of the 2nd harmonic filter. Note that 40 dB of notch, or better, is provided.

## The Care and Feeding of the R.F. Isolator

Trace #2 is the return loss of the filter based on mid scale reference of the analyzer display. This is a VSWR of 1.02:1.

Trace #3 is the response of the low pass filter. Note that it reaches 60 dB at just under 800 MHz and continues to over 1.2 GHz.

Trace #4 is the return loss of the low pass filter, showing a 26 dB or more R/L, a VSWR of 1.1:1 or better.

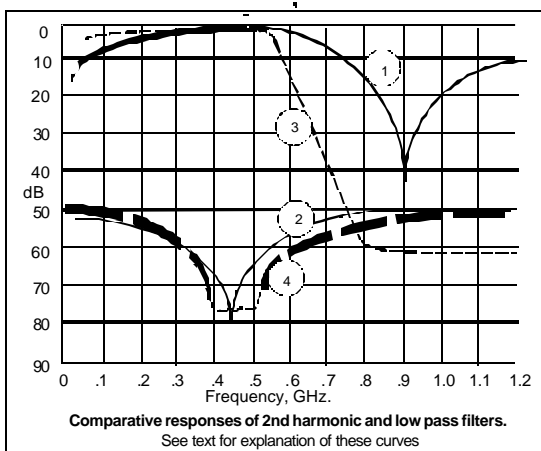

Figure 13

**Miscellaneous Notes:** The following is a collection of various subjects with appropriate comments:

**Band Pass & Pass-Reject Cavities:** It was noted earlier that a band pass cavity following an isolator will provide at least 40 dB of 2nd harmonic rejection. A pass-reject (pass-notch) cavity such as found in the most popular VHF and UHF antenna duplexers will provide little or no attenuation of harmonics which might require a 2nd harmonic or low pass filter at the isolator's output.

**Isolators as Band Pass Filters:** Do not attempt to use an isolator as a band pass filter: The out of band response can be very broad and irregular. Remember, isolators are used to provide rejection of coupled or reflected signals from other transmitter power amplifiers.

**Multi-frequency Transmitters:** Where a switchable multi-frequency transmitter is used, select an isolator having sufficient bandwidth for the range of channels and use a low pass filter. Added broad range isolation can be provided with a band-pass filter, as needed.

**Isolators as T-R Switches:** Often, we are asked if an isolator will work as a duplexer or "T-R Switch". At extremely low power and in certain microwave system applications this can be successful, but at lower frequencies (below 1 GHz) and at system power more than 1 watt or so, 20-35 dB is seldom adequate for TX to RX noise and carrier protection.

**Using Isolators in Digital Systems:** The majority of digital wireless formats use some form of transmission of a bit stream on which voice and/or data are applied to modify phase, amplitude, relative position or other means of application of information. A given digital bit string may derive several information channels, but still consists of a single string of bits occurring at a relatively high baud rate and at a given radio frequency.

Isolators are sufficiently linear to meet the needs of these applications, however, the effect of phase displacement must be considered where coherent systems are concerned. Further, much as with "analog" types of channel usage, once the individual channels are derived several can be coupled to common antennas using more or less common transmitters combining techniques. As in analog systems, do not attempt to use an isolator where more than one set of bits are being transmitted on separate frequencies.

**Use of Analog and Digital Systems on Common Sites:** Currently, many FM (analog) systems are being changed out to digital systems, more or less on a channel by channel basis. This has resulted in a mix of

## The Care and Feeding of the R.F. Isolator

both kinds of systems on most sites and in some cases has resulted in new problems.

Digital bits can heterodyne with analog carriers to produce what can be called "digital I.M." The effect of this on a digital receiver is that erratic reception can occur, causing abrupt loss of reception. In trunked or other controlled access digital systems various "retry" and "hold open" timing sequences are used to try to overcome this problem.

"Digital I.M." simply sounds like noise when present in the pass band of an FM receiver. The net effect is mostly to degrade analog system ranges due to the effective high site noise level that will occur, effectively reducing receiver sensitivity.

I.M. produced by two or more analog transmitters that might fall on a digital receiver's frequency will often result in system disconnect. By comparison, the recovered audio from digital systems is clearer and without noise, but will have less mobile or portable range compared to FM analog modulation systems, which can provide usable communications under multi-path and similar fading conditions.

-----  
**Acknowledgment.** This bulletin is intended to upgrade and replace the EMR Corp. pamphlet with the same title, first made available in March 1988.  
-----